

DEMA SURE-MEASURE DISPENSER MODEL 302-1 (1 fl. oz.), or 302-2 (2 fl. oz.) INSTALLATION INSTRUCTION

1. PARTS:

- | | |
|-------------------------------------|-----------------------------------|
| A. Pump Assembly | C. Plastic tubing, 8' long |
| B. 3 sheet metal screws in envelope | D. Ceramic weight & foot strainer |

2. INSTALLATION:

ALWAYS MOUNT PUMP ABOVE THE CHEMICAL AND NEVER USE THE PUMP WHEN LOCATED BELOW THE CHEMICAL.

Mount pump on wall using the screws provided. Connect one end of the plastic tubing to inlet. Tubing may be cut to any convenient length before dropping into chemical container. The ceramic weight may be pushed over the end of the tubing, and then foot strainer pushed into the end of the hose. The ceramic weight will hold the end of the hose toward the bottom of the container, and the foot strainer will hold the weight on.

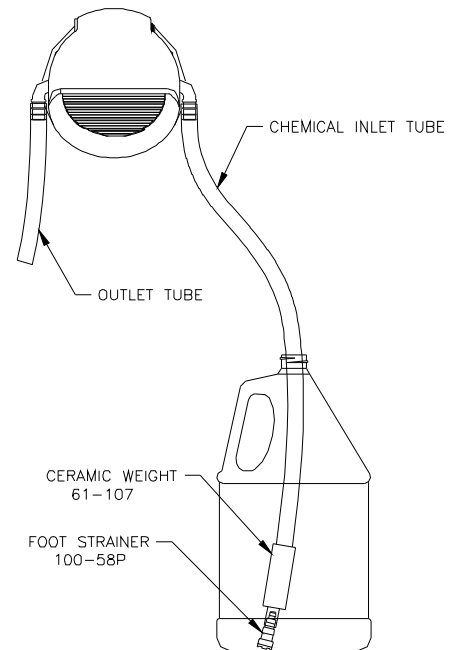
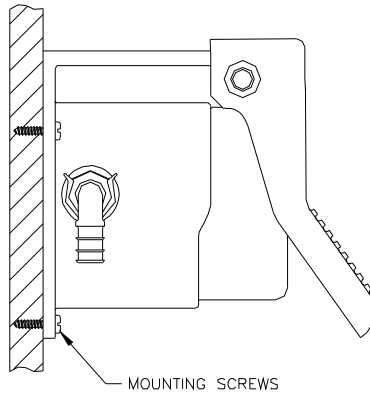

3. OPERATION: WARNING: USE CARE WHEN HANDLING HAZARDOUS CHEMICALS.

Push the pump handle to prime the inlet tubing. Once primed, the pump will deliver the designated amount of chemical with each full stroke.

PARTS LIST	
PART NO.	DESCRIPTION
100-12L	VINYL TUBE 1/2 O.D. X 8' LG
61-107	CERAMIC WEIGHT
100-58P	FOOT STRAINER

4. SERVICING: Flush with warm water to dissolve any dried fluid.

CAUTION: WHEN SERVICING UNIT BE SURE THAT REPLACEMENT PARTS HAVE BEEN INSTALLED ACCORDING TO DRAWING.

RETURNS:

NO MERCHANDISE MAY BE RETURNED FOR CREDIT WITHOUT DEMA'S WRITTEN PERMISSION. RETURN MERCHANDISE AUTHORIZATION NUMBER REQUIRED IN ADVANCE OF RETURN.

WARRANTY:

DEMA products are warranted against defective material and workmanship under normal use and service for one year from the date of manufacture. This limited warranty does not apply to any products which have a normal life shorter than one year or failure and damage caused by chemicals, corrosion, improper voltage supply, physical abuse, or misapplication. Rubber and synthetic rubber parts such as "o"-rings, diaphragms, squeeze tubing and gaskets are considered expendable and are not covered under warranty. This warranty is extended only to the original buyer of DEMA products. If products are altered or repaired without prior approval of DEMA, this warranty will be void.

Defective units or parts should be returned to the factory with transportation prepaid. If inspection shows them to be defective, they will be repaired or replaced without charge, F.O.B. factory. DEMA assumes no liability for damages. Return merchandise authorization number, to return units for repair or replacement, must be granted in advance of return.

DEMA SURE-MEASURE DISPENSER MODEL 302-1 (1 fl. oz.), or 302-2 (2 fl. oz.) INSTALLATION INSTRUCTION

DEMA MODEL 302 PUMP

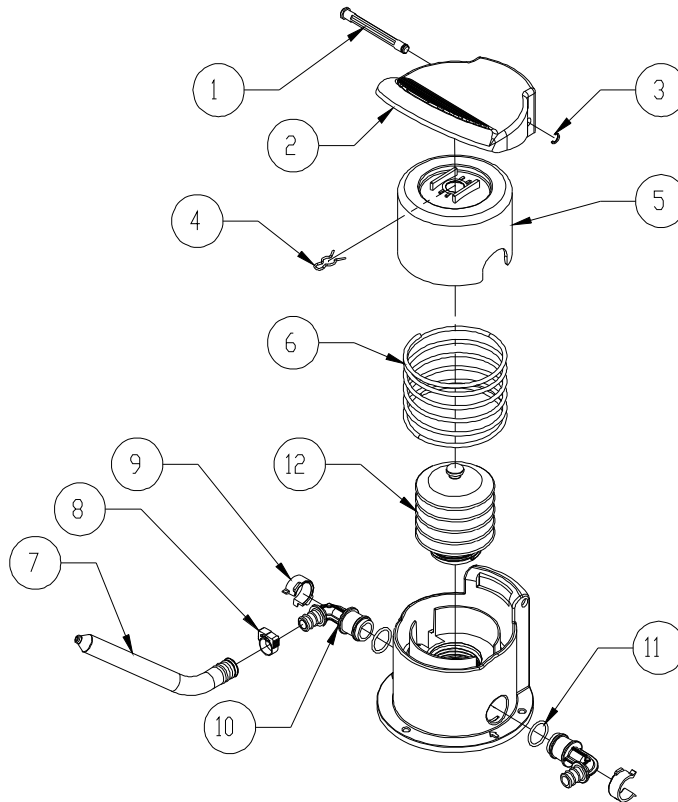

NO.	PART NO.	DESCRIPTION
1	30-27	Hinge Pin
2	30-25	Handle
3	30-32	Snap Ring
4	30-33	Hairpin Clip
5	30-26	Cover
6	30-31-1	Spring
7	30-80-1	Spout (optional)
8	16-9-4	Spout Clamp (optional)
9	30-28	Elbow Retainer
10	30-29	Elbow
11	30-35 30-35S 30-35V	O-Ring EPDM (black – for 302-1E and 302-2E) O-Ring Silicone (burnt orange – for 302-1S and 302-2S) O-Ring Viton (brown – for 302-1V and 302-2V)
12	30-36	Bellows